

RECOMMENDED PCB FOOT PRINT

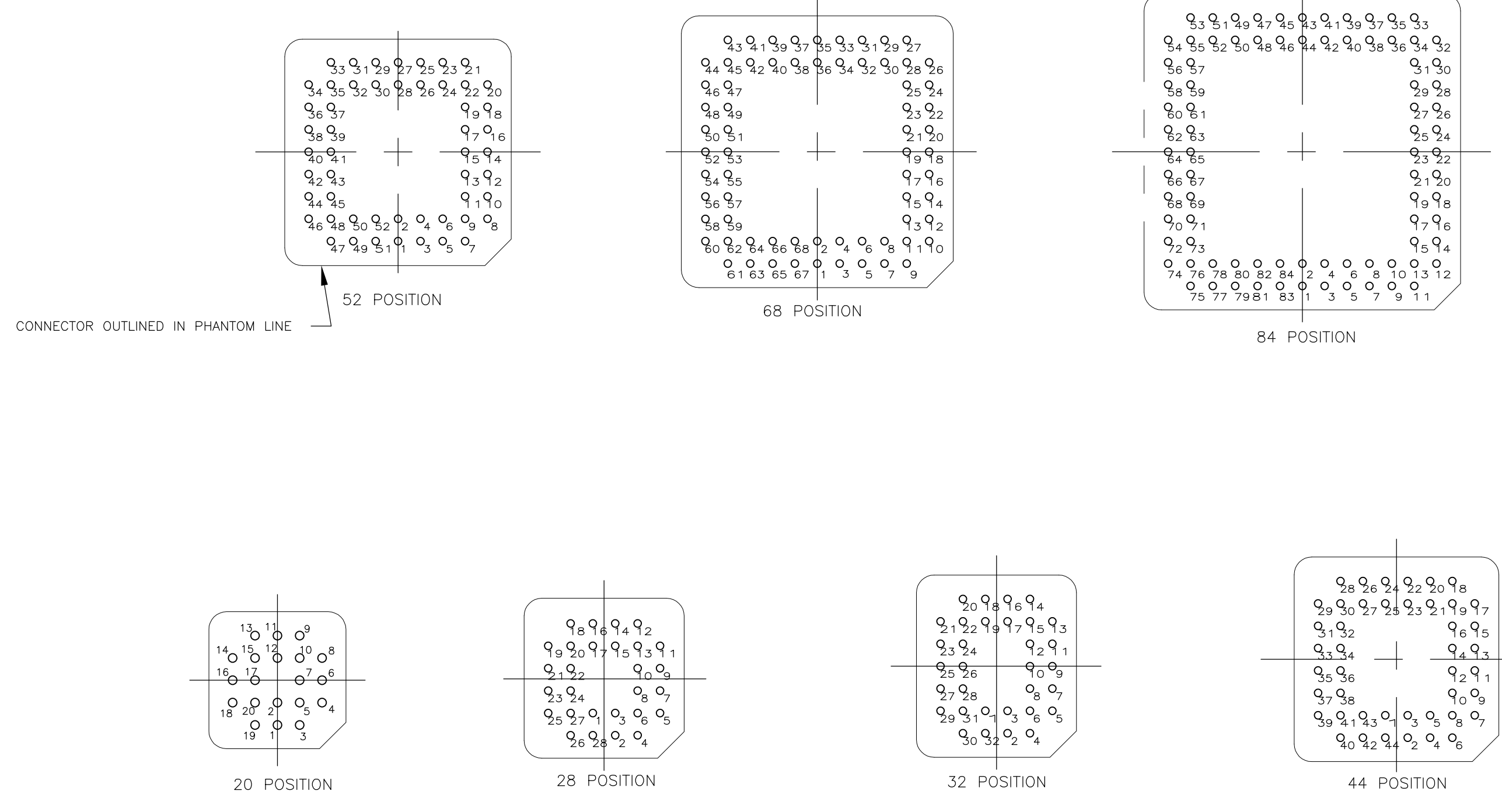
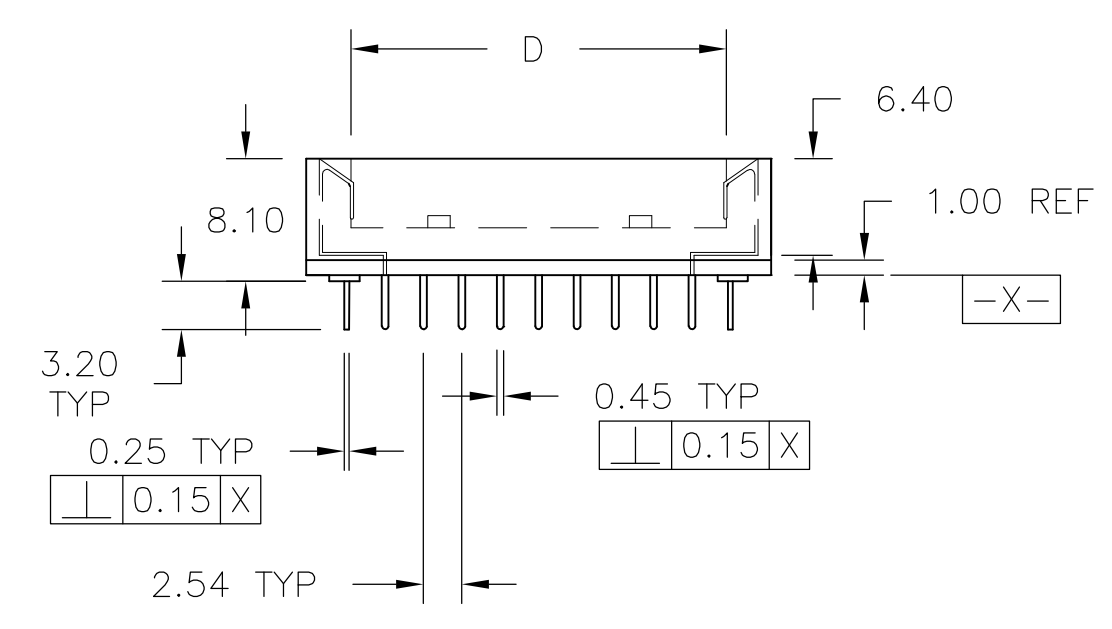

RECOMMENDED CIRCUIT CONFIGURATION VIEWED FROM COMPONENT SIDE OF CIRCUIT

- 1 MATERIAL:
HOUSING - THERMOPLASTIC UL94 V-0.
CONTACT - PHOSPHOR BRONZE.
- 2 FINISH: CONTACT PLATING: 1.52 μm 90/10 BRIGHT OR MATTE TIN-LEAD OVER 0.51 μm NICKEL ALL OVER.
- 3 PLASTIC LEADED CHIP CARRIER MUST CONFORM TO JEDEC SPECS. MS-016 & MS-018.
- 4 SPECIFICATION SUBJECT TO CHANGE WITHOUT NOTICE. CONTACT TYCO ELECTRONICS FOR THE LATEST SPECIFICATIONS.
- 5 FINISH: CONTACT PLATING 2.54 μm BRIGHT OR MATTE TIN OVER 1.27 μm NICKEL, ALL OVER.
- 6 ROHS 2002/95/EC COMPLIANT

PERFORMANCE INFORMATION		
TEST DESCRIPTION	REQUIREMENT	TEST SPECIFICATION
CONTACT RESISTANCE	20 MILLIOHMS MAX INITIAL, 40 MILLIOHMS MAX FINAL AFTER VIBRATION OR HUMIDITY.	MIL-STD-202G METHOD 307
INSULATION RESISTANCE	1,000 MEGAOHMS MIN INITIAL, 500 MEGAOHMS MIN AFTER HUMIDITY.	MIL-STD-202G METHOD 302
DIELECTRIC WITHSTANDING VOLTAGE	500 VAC BETWEEN ADJACENT CONTACTS, 1 MINUTE HOLD. NO EVIDENCE OF BREAKDOWN OR FLASHOVER AFTER HUMIDITY.	MIL-STD-202G METHOD 301
VIBRATION	10-55-10 HZ PER MINUTE, 1.5mm AMPLITUDE, 2 HOURS IN EACH DIRECTION. 100 nsec. MAX DISCONTINUITIES OR LOOSENING OF PARTS. MUST PASS CONTACT RESISTANCE.	EIA-364-28 CONDITION 1
DURABILITY	30 CYCLES NO VISIBLE DEFECTS, CONTACT RESISTANCE 40 MILLIOHMS MAX.	EIA-364-09
MATING FORCE	425 GRAMS (15 OZ) MAX PER CONTACT. INSERT AT CONSTANT SPEED OF 25mm PER MINUTE.	MIL-STD-1344A METHOD 2013.1
UNMATING FORCE	10 GRAMS (.35 OZ) MIN PER CONTACT. WITHDRAW AT CONSTANT SPEED OF 25mm PER MINUTE.	MIL-STD-1344A METHOD 2013.1
COLD TEST	TEMPERATURE: -40°C±3°C DURATION: 48±1 HOURS RESISTANCE VALUE AFTER TEST 40mΩ. APPEARANCE SHALL NOT BE DISTINCT DAMAGE.	JIS-C-0020
HIGH TEMP TEST	TEMPERATURE: 85°C±3°C DURATION: 96 HOURS RESISTANCE VALUE AFTER TEST 40mΩ. APPEARANCE SHALL NOT BE DISTINCT DAMAGE.	JIS-C-0021
CONTACT RETENTION FORCE	300 GRAMS (10.5 OZ) MIN PER CONTACT. CONTACT PULLED AT CONSTANT SPEED OF 25mm PER MINUTE.	ANSI/EIA-364-29
HUMIDITY	95 HOURS AT 90-95% RELATIVE HUMIDITY AT 40°±2°C. MUST PASS INSULATION RESISTANCE, DIELECTRIC WITHSTANDING OR CONTACT RESISTANCE.	JIS-C-0022
SOLDERABILITY	95% MINIMUM COVERAGE. IMMERSE FOR 3±.5 SECONDS IN 260°±5°C BATH.	JIS-C-0050
CURRENT RATING	1 AMP	-
VOLTAGE RATING	250V	-
OPERATING TEMPERATURE RATING	-20°C TO 85°C	-

29.42	29.42	46.15	25.40	25.40	35.88	35.88	1248	TUBE	84	1-822473-7
24.38	24.38	39.00	20.32	20.32	30.80	30.80	1596	TUBE	68	1-822473-6
19.30	19.30	31.50	15.24	15.24	25.72	25.72	2254	TUBE	52	1-822473-5
16.74	16.74	27.50	12.70	12.70	23.18	23.18	2800	TUBE	44	1-822473-4
13.94	11.36	22.65	10.16	7.62	20.54	18.10	4060	TUBE	32	1-822473-3
11.46	11.46	20.70	7.62	7.62	18.10	18.10	4620	TUBE	28	1-822473-2
8.90	8.90	17.20	5.08	5.08	15.56	15.56	6552	TUBE	20	1-822473-1
29.42	29.42	46.15	25.40	25.40	35.88	35.88	1248	TUBE	84	822473-7
24.38	24.38	39.00	20.32	20.32	30.80	30.80	1596	TUBE	68	822473-6
19.30	19.30	31.50	15.24	15.24	25.72	25.72	2254	TUBE	52	822473-5
16.74	16.74	27.50	12.70	12.70	23.18	23.18	2800	TUBE	44	822473-4
13.94	11.36	22.65	10.16	7.62	20.54	18.10	4060	TUBE	32	822473-3
11.46	11.46	20.70	7.62	7.62	18.10	18.10	4620	TUBE	28	822473-2
8.90	8.90	17.20	5.08	5.08	15.56	15.56	6552	TUBE	20	822473-1

FINISH	E	D	C	B2	B1	A2	A1	TOTAL QUANTITY PER CARTON	PACKAGING	NO. OF POSITIONS	AMP PART NUMBER
1											

THIS DRAWING IS A CONTROLLED DOCUMENT.

DRN: A.HOLT 26AUG99
 CHK: B.KUHNLY 25MAR99
 APPO: B.KUHNLY 25MAR99

TOLERANCES UNLESS OTHERWISE SPECIFIED:
 0 PLC ±
 1 PLC ±
 2 PLC ± 0.20
 3 PLC ±
 4 PLC ±
 ANGLES ±

PRODUCT SPEC: SEE NOTES
 APPLICATION SPEC: NONE

SIZE: A1 CAGE CODE: 00779 DRAWING NO: 822473
 WEIGHT: CUSTOMER DRAWING

Tyco Electronics Corporation
 Harrisburg, PA 17105-3608

SOCKET ASSEMBLY, PLCC, SOLDER TAIL

SCALE: 2:1 SHEET 1 OF 1 REV H